

Ebac 15

UK User Manual
Accessories
Warranty Registration

Here at Ebac, we love hearing
what our customers think of our
products!

How did we do? Review us

on  Trustpilot

You can leave a review @
www.trustpilot.com/www.ebac.com

Introduction

Your dehumidifier will remove excess moisture from the air in your home. To obtain the maximum benefit from your dehumidifier please read these instructions carefully.

Important

Your dehumidifier is packed in a plastic wrapping - please ensure that it is disposed of safely and where it will not be a danger to children.

During installation and maintenance, respect the precautions indicated in the manual, and on the labels applied inside the units, as well as all the precautions suggested by good sense and by the safety regulations in effect in your country.

Before operation

- Stand your dehumidifier upright for at least 2 hours prior to operating.
- Open the water container door, remove the water container - replace and close the door. This will reset the sensors which may have been activated during transit.

Positioning your dehumidifier

- Position in cooler areas such as the hallway or landing
- Position centrally in the home
- Leave interior doors open where possible
- Do not place next to a radiator or direct heat source
- Ensure the unit is on a flat surface

Once your condensation problem is under control, your dehumidifier will extract from 1 to 2.5 litres of water per day.

This appliance can be used by children aged from 8 years and above and persons with reduced physical, sensory or mental capabilities or lack of experience and knowledge if they have been given supervision or instruction concerning use of the appliance in a safe way and understand the hazards involved. Children shall not play with the appliance. Cleaning and user maintenance shall not be made by children without supervision.

Setting the controls

Humidistat

Initially set to maximum by turning the humidistat dial fully clockwise.

When signs of excess moisture (such as condensation) are reduced gradually turn the humidistat dial anti-clockwise until the unit just switches off.

If signs of excess moisture re-appear increase the humidistat setting. Alternatively if you are no longer suffering from excess moisture and your dehumidifier runs for long periods a lower setting can be selected. After adjusting the humidistat always allow 5 minutes for the unit to start dehumidifying.

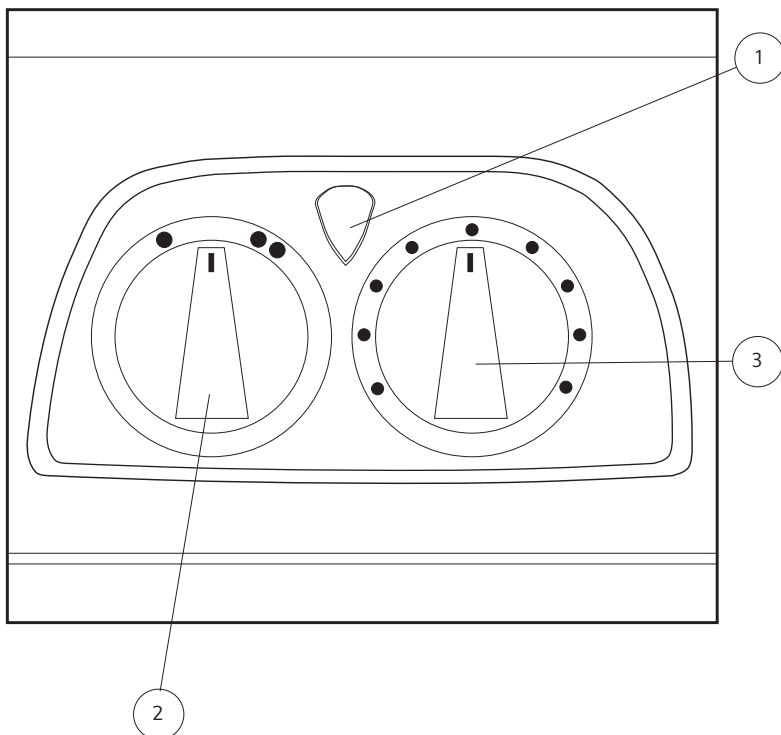

Dual Dial Models

- ① Power On and Container Full Indication
- ② Fan Speed Control
- ③ Humidistat

Fan Speed Control

Setting	Function
1	Low/Quiet Setting
2	High Setting for maximum extraction

To adjust fan speed
Turn the fan speed dial to desired position

Emptying the water container

The Red Light on the control panel will illuminate when the container is full. When this occurs water collection stops.

Open container door (fig a).

The container can be removed and emptied (fig b).

Replace the container with the outlet on the left and gently close the door.

Changing the filter

Your Ebac 15 has a filter to remove dust from the air.

This filter should be cleaned every month and replaced after 4 months. Failure to do this will reduce the performance of your dehumidifier and may over time lead to a permanent reduction in performance.

Remove the filter cartridge from the rear of the unit (fig c).

Clean the filter using a vacuum cleaner on a low power (fig d).

Replace the filter cartridge onto the rear panel.

Figure a

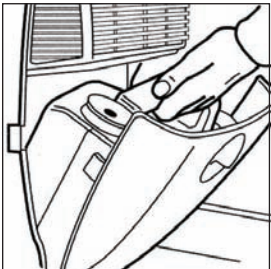

Figure b

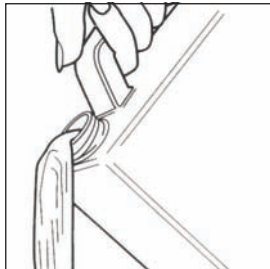

Figure c

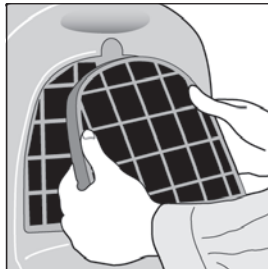
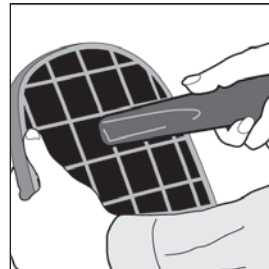

Figure d



Using the Permanent Drainage Facility

Your dehumidifier can be used in unattended dwellings such as holiday homes without emptying the water container. To use this facility you must order a permanent drainage kit.

Should you have any queries about the drainage kit please contact our helpline on 0345 805 0000.

Looking after your dehumidifier

Your dehumidifier requires very little maintenance, however, to maximise performance clean the filter every month (replacing every 4 months) and every 6 months you should check the drainage system as follows:

- a. Using a standard matchstick or small plastic bottle brush remove any residue from the water drain outlet above the water container (left hand side).
- b. Pull out the permanent drainage bung from the rear of the unit. This should then be pushed in and out a few times to remove any build up inside the drain tray (have a cloth or other absorbent material handy to catch the water). The bung should then be pushed fully home to reseal the drain tray.

Never use solvents or abrasive cleaners to clean your dehumidifier.

If your dehumidifier fails to operate

Always check the following list before requesting service.

Power-on indicator light is not illuminated

- a. Is the unit switched on at the mains. If necessary test the socket by plugging in another appliance.
- b. Check the fuse in the plug and if necessary replace with another 13 amp fuse.

Power indicator light is illuminated but the unit is not collecting water

- a. Is the humidistat setting too low, increase the setting.
- b. The water container may be full, empty the container.
- c. Ensure the water container is fitted.

If your dehumidifier fails to operate cont.

Reduced Water Extraction

- a. The humidistat may be set too low, if signs of condensation or dampness remain, increase the setting.
- b. The filter may be blocked, remove, clean and refit.
- c. After being installed all dehumidifiers will collect less moisture as initial excess moisture is removed. This is normal.
- d. The dehumidifier may be positioned next to a heat source, i.e., a radiator - reposition.

Dehumidifier collects water but is not preventing condensation

- a. The humidistat may be set too low, select a higher setting.
- b. Outside temperatures have dropped suddenly. The dehumidifier may take a few days to get the problem back under control.

Red Water Container Light remains on all the time and the dehumidifier is not running.

(Normal when the water container is full).

- a. Ensure the water container is not full.

Requesting Service

Before requesting service please read the section 'If your dehumidifier fails to operate'. If after following this advice you still experience problems please obtain the following information, then contact us on

0345 805 0000 (UK only).

- a. Model and Serial Numbers (located on a rating plate behind the water container).
- b. Your Name, Address, Postcode and Telephone Number.
- c. Where your dehumidifier was purchased
- d. Date of purchase
- e. If applicable any valid guarantee extension

In other countries please contact your national distributor or retailer.

Technical and Safety Information

Min. Operating Temperature: 3°C

Max. Operating Temperature: 35°C

Fuse Rating: 13 Amp

- Do not use the machine if the power cord or cabinet are damaged.
- If the machine is damaged or in need of repair please contact Ebac.
- Do not poke objects into any grilles on the machine.
- This machine complies with EMC/RFI directive EN60555 (BS800).
- Ebac Limited has a policy of constant development and, therefore, reserves the right to change specifications without prior notice.
- Do not use the machine without the permanent drainage bung in place on the back of the machine.
- Your dehumidifier should not be located in such a way that it will become an obstacle or hazard.
- Your dehumidifier should not be placed directly at the top of the stairs.
- To protect against electrical shocks, do not immerse unit, plug or cord in water, or spray with liquids
- Ebac would always recommend plugging the appliance directly into the mains where possible however an extension lead may be used if required. The extension lead should be rated at the correct current for the appliance, fuse protected and electrically safe. The extension must not be overloaded. It is the responsibility of the user to ensure all of these conditions are met. Ebac wouldn't accept any responsibility for malfunction due to the use of an extension.
- Ensure Power supply is RCD protected at 30mA.
- Do not put the unit close to heat-generating devices or near flammable and dangerous materials.

**WARNING! THIS PRODUCT CONTAINS R290 FLAMMABLE REFRIGERANT GAS.
READ THE SPECIFIC WARNINGS GIVEN IN THIS MANUAL.**

Warnings for using R290 refrigerant only

- The appliance contains R290 gas (A3 flammability classification).
- Do not use any means to accelerate the defrosting process.
- When cleaning the appliance this should be limited to the exterior panels and filter, following the guidelines within this manual. If the appliance is installed, operated or stored in a non-ventilated area, the room must be designed to prevent the accumulation of refrigerant leaks resulting in a risk of fire or explosion due to ignition of the refrigerant caused by electric heaters, stoves, or other sources of ignition.
- The appliance shall be stored in a well-ventilated area where the room size corresponds to the room area as specified for operation. (4 m²)
- The appliance shall be stored in a room without continuously operating ignition sources (for example: open flames, an operating gas appliance or an operating electric heater).
- Do not pierce or burn.
- Be aware that the refrigerants may not contain an odour.
- Appliance should be installed, operated and stored in a room with a floor area larger than 4 m².
- This appliance contains ≤90g of R290 refrigerant gas
- R290 is a refrigerant gas that complies with the European directives on the environment. Do not puncture any part of the refrigerant circuit.
- Compliance with national gas regulations shall be observed.
- Keep ventilation openings clear of obstruction.
- The appliance shall be stored so as to prevent mechanical damage from occurring.
- The appliance must be returned to the manufacturer Ebac for service or repair.







Caution: Risk of fire/flammable materials (Required for R290 units only)



IMPORTANT NOTICE: Read this manual carefully before installing or operating your new dehumidifier unit. Make sure to save this manual for future reference.

Explanation of symbols displayed on the unit:

	WARNING	This symbol shows that this appliance uses a flammable refrigerant. If the refrigerant is leaked and exposed to an external ignition source, there is a risk of fire.
	CAUTION	This symbol shows that the operation manual should be read carefully.
	CAUTION	This symbol shows that service personnel should be handling this equipment with reference to the installation manual.
	CAUTION	This symbol shows that information is available such as the operating manual or installation manual.

Accessories

Activated Carbon Filter Pack

Model no. DDA507

Contains 3 Activated Carbon Filters. Carbon filters are ideal for homes with pets or smokers as they remove odours from the air creating a more pleasant atmosphere. Note that this pack does not include the filter housing. The filter housing is available at an extra charge.

£15.99

Activated Carbon with Bactiguard Filter

Model no. DDA510

Contains 3 Activated Carbon with Bactiguard Filters. The Bactiguard's special formulation protects against germs and other airborne particles, killing all known bacteria and many fungi, ensuring a cleaner and healthier home. Note that this pack does not include the filter housing. The filter housing is available at an extra charge.

£17.99

Filter Housing

Model no. DDA108

The filter housing is specific to Ebac series dehumidifiers.

£4.99

Castor Kit

Model no. DDA268

Although lightweight and portable adding a castor kit to your dehumidifier makes it easier to move as it can be simply wheeled to a desired location.

£14.99

Drainage Kit

Model no. DDA110

The permanent drainage kit allows your dehumidifier to be used in unoccupied situations such as holiday homes, cellars etc without the need for the water container to be emptied

£9.99

Water Container

Model no. DDA200

Replacement water container in case anything should happen to the one supplied with your dehumidifier.

£19.99

Prices are subject to change. For the latest prices and special offers log on to

www.ebac.com

How to purchase

- Online

Log on to **www.ebac.com**

- Post

Complete and send the attached form to:
**Ebac Ltd, Ketton Way, Aycliffe Business Park, Newton
Aycliffe, County Durham, DL5 6SQ**

Accessory Details

Model No.	Accessory	Price	Total

Your Details

Title: Initials: Surname:

Address:

.....

.....

Postcode: Country:

Telephone: Mobile:

Email:

Your personal data will be used to process an accessory sale. Personal data is only used for marketing purposes with your explicit consent. You can use the form on page 10 to choose your optional preferences.

Payment Details

I enclose a cheque/postal order for

£ Payable to Ebac Ltd

+ £3.95 Postage and Packaging

Warranty Registration

Thank you for purchasing an Ebac Dehumidifier. Your dehumidifier is covered by a standard one year warranty from the date of purchase. Registration of your unit ensures you can take full advantage of your warranty so don't hesitate and register today.

How to Register

There are two simple methods of registering your Ebac Dehumidifier Warranty

- **Online** Log on to **www.ebac.com/warranty**
- **Post** Complete and send the attached form to:
**Ebac Ltd, Ketton Way, Aycliffe Business Park, Newton
Aycliffe, County Durham, DL5 6SQ**

Why Register?

There are three Reasons to register your Ebac Dehumidifier:

1. You can take full advantage of your Ebac warranty.
 - Fast repair service carried out by Ebac with the unit collected and delivered from and to the place most convenient to you.
 - All parts and labour included.
2. Your details are on record which enables us to help you much faster.
3. You can choose to sign up to our mailing list to receive the latest product information and up to date offers.

What's covered?

- Your dehumidifier will receive unlimited repairs for any mechanical failure within the period of the warranty.
- The costs associated with the collection, repair and return delivery of the dehumidifier.
- The warranty covers dehumidifiers in domestic use in Great Britain and Northern Ireland.
- Visit www.ebac.com/warranty for Terms and Conditions.

What's not covered?

- The warranty does not cover wear and tear to the unit exterior or air filter.
- You may be charged if no fault is found or the fault is due to user error.
- The warranty does not cover accidental damage.

In the event of a breakdown please call our Customer Service Desk on 0345 805 0000

This warranty does not affect your statutory rights as a purchaser.

About You

Title: Initials: Surname:

Address:

.....

.....

Postcode:

Telephone: Mobile:

Email:

About Your Dehumidifier

Model No.* Serial No.*

*Located behind the water container or on the rear panel

Date of Purchase: / / Purchase Price (£):

Where did you buy your unit:

Warranty Required

Register my one year warranty

Register and extend my warranty to five years and I have enclosed a cheque for £45 payable to Ebac Ltd

ONLY AVAILABLE IF APPLIED FOR WITHIN 30 DAYS FROM THE DATE OF PURCHASE

Choose your optional marketing preferences

You can choose to sign up to our mailing list to receive the latest product information and up to date offers. Please tick any of the below boxes you would like to be contacted about:

News and Information

To carry out Product Testing

Special Offers and Promotions

Helpful Advice and Articles

Reviews and Feedback

Product Surveys

To help Ebac with Product Development

None

Please select how you would like to receive your marketing preferences below:

Email

Phone

Post

Text Message



Ebac Limited

Ketton Way, Aycliffe Business Park, Newton Aycliffe, County Durham, DL5 6SQ

Tel: 0345 805 0000 (GB)

Fax: +44 (0) 1388 609845

www.ebac.com



Where you see this symbol on any of our electrical products or packaging, it indicates that the relevant electrical products should not be disposed of as general household waste in Europe. To ensure the correct waste treatment of the product, please dispose of it in accordance with any applicable local laws or requirements for disposal of electrical and electronic equipment. In so doing, you will help to conserve natural resources and improve standards of environmental protection in treatment and disposal of electrical waste.



Made in Great Britain

Part NO: DEL079